



Innovation Drives Performance



www.innovance.com | 507.377.8910



Innovance is the holding company for a portfolio of five, 100% employee-owned manufacturing companies located in Minnesota and Wisconsin. Formed in 2004, the Innovance name comes from two defining characteristics of the organization – innovation and performance. Our 400+ Employee-Owners strive to make every customer interaction a great one.

We collaborate across the organization to grow our employee and customer share value, by focusing on delivering an outstanding customer experience. Our unique and varied mix of industrial manufacturing capabilities assures our customers we are committed to developing solutions that solve most customer challenges.

Global Footprint

The four Innovance OEM companies combined dealer and strategic alliance networks reach into vast areas around the world. Our equipment can be found hard at work in dozens of countries. In addition, our contract manufacturing company, Lou-Rich, has built a wide variety of parts whose products are used all over the globe.



● Dealer Locations
■ Active Service Areas

Core Values

- Conduct business with integrity and respect.
- Embrace innovation, technology, and performance.
- Provide stimulating careers with a healthy work-life balance.
- Ensure a friendly, safe, and secure working environment.
- Enhance employee's knowledge, skills, and abilities.
- Be socially and environmentally responsible.

Mission Statement

To lead, nurture, and grow a team of industrial manufacturing companies committed to making our customers' products better.



VISIT OUR SITE



Innovance Company Structure

At Innovance we provide many of the services every business needs to function and thrive. Shared among all Innovance companies, these services offer a cost-effective and highly engaged delivery of professional expertise. We do this so each of our business units can focus on building the best products for our customers.

Innovance shared services currently fall into six general categories.



Innovance R&D Group

In 2022, we established the Innovance R&D group in Minneapolis, MN, dedicated to driving advancements in the product lines of our OEM companies. This team is equipped with an array of capabilities and services, including 3D Printing, Automation & Programming, SolidWorks Simulation, and Vibration Analysis. Focused primarily on the research and development of new technologies and processes, the Innovance R&D group plays a crucial role in distinguishing us from competitors. Their work ensures continuous improvement, not only in the development of new products and services but also in the enhancement of our existing offerings.



Message from the President & CEO



Innovance and its over 400+ talented employee-owners combine innovation with performance to create value for our customers. Our shared ownership ensures a collaborative approach to finding the best solutions to overcome any business challenge. We listen to understand your needs then align our approaches to help meet your objectives. This principle drives our dedication to exceeding your expectations – making a real impact.

Our portfolio of industrial machine and contract manufacturing companies offers a wealth of options and proven paths for your business success. Challenge us to find innovative ways to create value and expect us to deliver on time and with exceptional quality.

On behalf of all the employee-owners of Innovance, thank you for your trust in our company and our capabilities that enable you to realize sustainable success. We will strive to earn your business every day.

Merritt Becker, Innovance President and CEO

Innovance Company History

While Innovance started in 2004, our brands have been operating as far back as 1946. Created as a way to expand and diversify the flagship business of Lou-Rich through acquisitions, Innovance continues to grow its portfolio of companies providing stability and security to all its Employee-Owners.

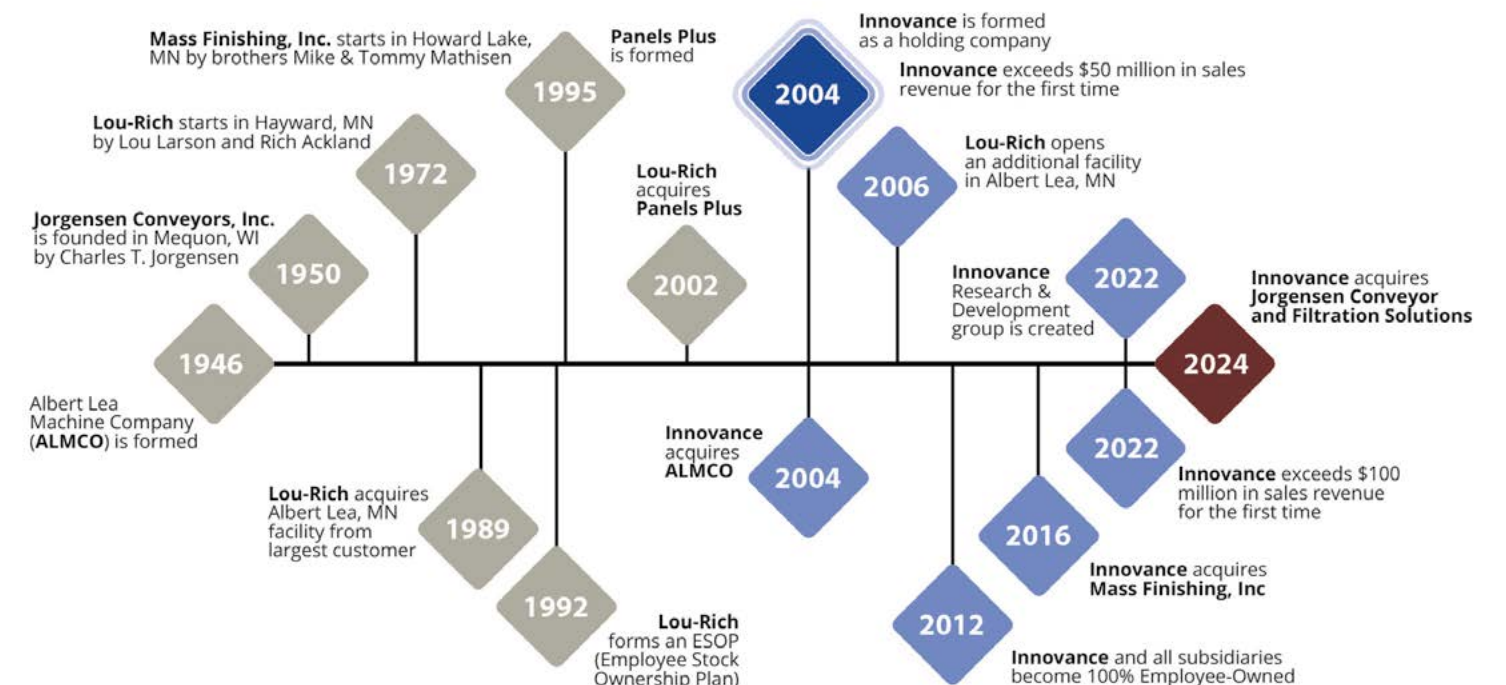



www.almco.com | 800.521.2740

ALMCO has been in business for over 75 years making and selling the best industrial finishing and washing systems in America. In addition to a robust line of standard products, ALMCO also designs and manufactures custom equipment to meet specific requirements. Leading companies in automotive, aerospace, medical, ammunition, construction, fasteners, and many other industries trust ALMCO for high-quality equipment, media, and ongoing service. ALMCO guarantees the same finish in production as produced in our lab when you follow the process formula and use ALMCO equipment and media.

What We Do

- Industrial Finishing Equipment
- Parts Washing & Drying Equipment
- Spindle Finishing Equipment
- Conveyor Systems
- Sediment Tanks
- Free Sample Processing
- Media & Compound
- Parts Replacement and Field Service

Vision Statement

To provide every customer with a completely satisfying experience.



Industries Served



Automotive/Transportation



Fabricated Metal Products



Weapons/Munitions



Industrial Equipment



Aerospace/Aircraft



VISIT OUR SITE





Conveyor and Filtration Solutions

www.jorgensenconveyors.com | 800.325.7705

Founded in 1950, Jorgensen Conveyor and Filtration Solutions has been a leader in conveyor and filtration technology for over seven decades. Based in Mequon, Wisconsin, we specialize in producing high-quality conveyors, coolant filtration systems, material handling equipment, and chip processing equipment, tailored to meet the diverse needs of our customers. Our enduring commitment to innovation and excellence has established Jorgensen as a trusted partner to OEM machine builders, importers of machines, distributors, and end users in a wide range of industries. Serving sectors such as automotive, aerospace, energy, and agriculture, we provide comprehensive solutions that enhance efficiency and productivity in manufacturing processes.

What We Do

- Conveyors & Material Handling Equipment
- Coolant Filtration Systems
- Chip Processing & Metal Recycling Equipment
- Custom-engineered Conveyor & Filtration Systems
- Conveyor and Filtration Accessories

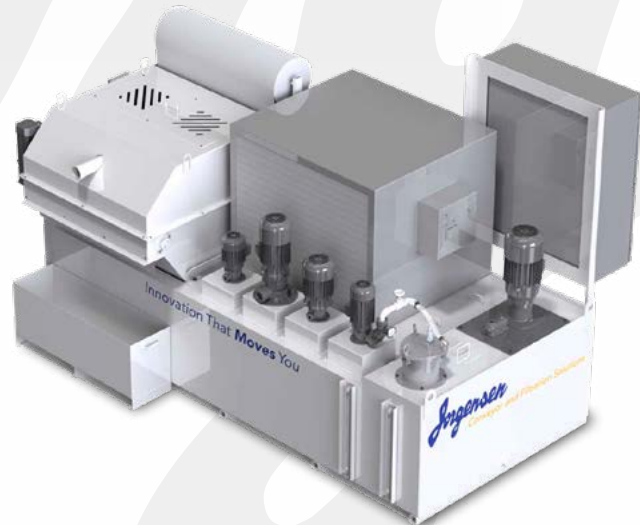

Industries Served



Automotive



Aerospace



Energy/Heavy Industry



Contract Machine Shops



Material Handling



VISIT OUR SITE



In business since 1972, Lou-Rich Inc. is a fully integrated contract manufacturer specializing in complex projects. We provide precision machining, metal fabrication, assembly, and sourcing solutions to a variety of industries, including some of North America's largest OEMs. Companies of all sizes trust Lou-Rich with their most vital and complex manufacturing projects. We can often replace multiple other suppliers because of the wide range of robust contract manufacturing services we offer. With our machining centers, metal fabrication & welding, paint, and assembly services all under one roof, chances are we can handle any project you have.

What We Do

- Complex Metal Fabrication
- Manual & Robotic Welding
- Precision Machining
- Powder Coat & Wet Painting
- Sub-Assembly & Full Product Assembly
- Design for Manufacturability
- Supply Chain & Inventory Management

Vision Statement

To be the best employee owned contract manufacturing company in North America.



Industries Served



Medical Equipment



Ag Equipment



Food Service Equipment



Industrial Equipment



Hybrid Electric Transportation Components



VISIT OUR SITE



www.massfin.com | 888.260.6277

Mass Finishing, Inc. (MFI) is an industry leader in high-energy centrifugal barrel polishing and deburring equipment. Designed to finish and deburr parts in mass quantities in a fraction of the time it would take to finish just one part by hand. With over two decades of experience, MFI has developed thousands of processes to handle virtually any troublesome job. MFI serves customers in many industries including medical, aerospace, dental, jewelry, automotive, and firearms. Send in your sample parts to our lab, and we will develop a process to efficiently get the exact finish needed.

What We Do

- High-Energy Centrifugal Barrel
- Centrifugal Disc Equipment
- Media Separators
- Sediment Tanks
- Free Sample Processing
- Media & Compound
- Parts Replacement and Field Service

Vision Statement

To continue to be the leading manufacturer of High-Energy Centrifugal Finishing Machinery by using our commitment to excellence and our personable approach.



Industries Served



Automotive/Transportation



Industrial Components



Weapons/Munitions



Dental/Medical Device



Aerospace/Aircraft



VISIT OUR SITE



We Nailed It

www.panplus.com | 866.726.7587

Panels Plus is the leader in North America for the design and manufacture of panelizing equipment for constructing wall panels, floor cassettes and related subcomponents. For more than 20 years, progressive builders in the off-site, modular, and prefabricated building industries have trusted Panels Plus. Virtually every piece of equipment we have ever built is still in operation. Our equipment helps builders reduce labor costs while improving product consistency and production efficiency.

What We Do

- Framing Stations
- Squaring Stations
- Sheathing Stations
- Combo Station
- Light Gauge Steel Systems
- Floor Cassette Station
- Pneumatic Tilt Table
- Production Lines
- Installation and Service

Vision Statement

To provide every customer with a completely satisfying experience.



Industries Served



Prefabricated Homes



Off-Site Construction



Modular Homes



Storage Sheds



VISIT OUR SITE



